



Builder Specifications for Solar Ready Homes

This document specifies the essential elements required to make a new home ready for the future installation of roof-mounted solar domestic hot water and photovoltaic (PV) systems.

A Solar Ready new home is a home that is equipped for the future. A few simple considerations in the design and construction of a new home can result in significant savings in the future when the homeowner is ready to install a solar energy system.

Solar Ready is an initiative managed by Natural Resources Canada's Office of Energy Efficiency, New Housing Program.

Required Elements for Solar Ready	Builder Benefits of Solar Ready
<ol style="list-style-type: none"> 1. A suitably sized, orientated and unobstructed location on the roof for future installation of solar panels. 2. A sealed conduit(s) or approved line set and conduit roughed in from the attic or roof to the mechanical room. 3. Pre-installed plumbing valves and fittings on the hot water heater to simplify the installation of a solar hot water tank. 4. An electrical outlet at the planned tank location and wall space for PV controls. 5. Identified locations of future components on construction plans and owner's diagram. 6. Solar Ready labels on the conduit(s) and hot water heater. 	<ul style="list-style-type: none"> • Solar Ready is easy to do, easy to understand and easy to sell. • It is a great way to start a conversation about energy efficiency options with homebuyers. • It is an inexpensive and cost effective way to show a commitment to green building. • It provides market differentiation and access to the Solar Ready marketing materials. • It provides opportunities to educate consumers about solar energy systems and sell them as an option. • Homebuyers view it as part of your overall commitment to quality. • Additional information is available on the website: www.newhomes.nrcan.gc.ca

Consumer Benefits of Solar Ready

- Solar Ready is a cost effective way to be prepared for a future rise in energy costs.
- Future installations will be easier and energy savings will be optimized.
- Planning up front may eliminate the need for future building permits.

Solar Ready is a simple yet effective way for builders and homebuyers to build for the future.

1. Roof Location for Solar Panels

In most residential applications, roof-mounted equipment is the most cost effective way to install solar energy systems. The “ideal” location for much of Canada would be on a south facing roof with a 9/12 pitch. However, less than a 25% drop in performance from this ideal can be achieved with orientations between due west through to south-east and roof pitches between 5/12 and 12/12. Some panels may be installed on a rack to adjust the pitch. Shading of the designated area by dormers, adjacent houses or trees must be avoided.

Roof Plan: location options A&B

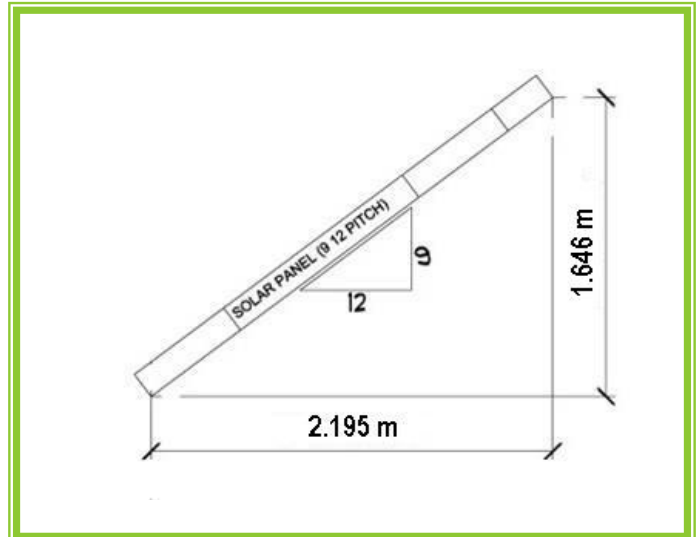
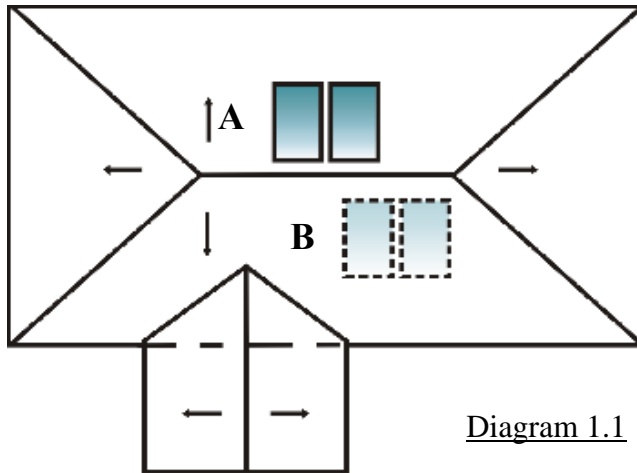

1. Solar Ready Program Requirements – Roof Location:

- 1.1 For each house model, provide a minimum of 9.3 m² (100 sq. ft.), with no dimension less than 2.7 m (9'), of unobstructed roof;
- 1.2 Provide an orientation of the roof location anywhere from south-east to west;

Note: If the orientation of the model is not known then show 2 locations on opposite sides of the roof (180 degrees apart). This way, however the model is placed, one of the locations will be pointing between south-east and west. See diagram 1.1 as an example.
- 1.3 Provide a roof pitch in the designated location of no less than 5/12 and no more than 12/12.

Helpful Hints for the Roof Location

- Vaulted or cathedral ceilings may mean the attic isn't accessible so you may need to exit the roof and flash, cap and seal the conduit(s).
- Any skylights that are located within the designated area will need to be relocated.
- The location of roof vents may need to be altered to accommodate the panels.
- Typical solar panels will not weigh enough to require truss changes, however, check with your truss manufacturer or local building official for point load requirements.

2. A Conduit or Approved Line Set from the Roof to a Mechanical Room:

The goal is to run a conduit or pair of conduits from an accessible attic space to an accessible location in the mechanical room to allow future installation of wires for photovoltaic systems and/or fluid and sensor lines for solar thermal systems. While wires are flexible, the current technology for solar thermal lines will require a nearly straight conduit, i.e. no elbows. Central vacuum tubing is suggested. Builders should consult their local building officials and electrical safety authority to ensure code compliance.

Diagram 2.1 Sample Mechanical Room Plan

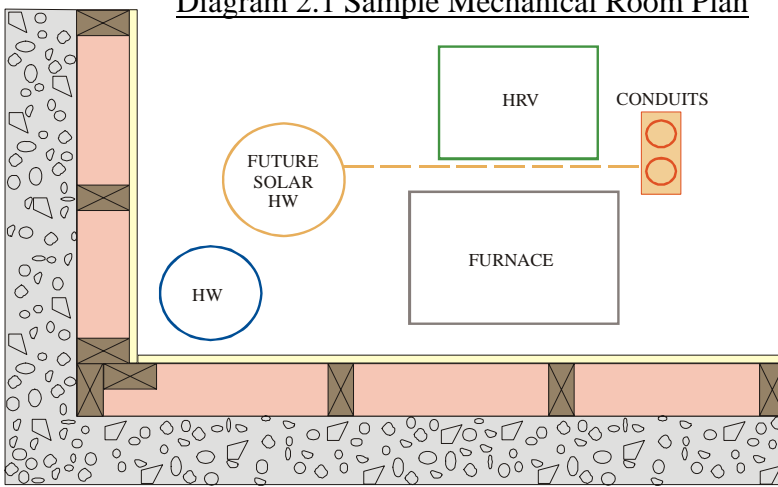

2. Solar Ready Program Requirements – Conduit Provisions:

Provide two 5 cm (2”) diameter or one 10 cm (4”) diameter plastic pipe(s) that run from an accessible attic to a planned mechanical room or other accessible room. Additionally:

- a. the pipes must be relatively straight;
- b. the ends of the pipe(s) must be capped (not glued), with appropriate manufactured caps, the caps must be sealed in the attic and the space around the pipe(s) must be sealed to the vapour barrier to prevent air leakage;
- c. in the attic, the pipe(s) must terminate above the top of the insulation with at least 0.9 m (3’) of vertical workspace above the pipes to allow for access;
- d. if the attic is not accessible, the conduit(s) must exit the roof and be capped, sealed and flashed appropriately; and
- e. in the basement, the pipe(s) must not terminate in an area where they will be obstructed by duct work, major plumbing pipes or room finishes, the pipes should extend below the floor joists and the pipes should be labeled. Consult your local building official for fire separation requirements.

Note: If you know the specific requirements of the solar system that will be installed it is acceptable to run the actual line sets needed rather than a simple conduit. An empty 5 cm (2”) conduit will be required to allow the option of installing a future PV system.

Helpful Hints for Conduit Provisions:

- In a two storey home, the provision of a wall that goes from the mechanical room to the attic will facilitate conduit runs. Many plans will need some redesign to get a common stacked wall location.
- Design the stacked wall location such that it does not fall directly below a truss.
- Two 5 cm (2") pipes provide greater installation flexibility than a single 10 cm (4") conduit. 5 cm is flexible enough to allow slight bends. Elbows are not acceptable.
- The plastic conduit is essentially a placeholder. Where required by code, a secondary approved conduit could be run inside it at the time of system installation.
- Running the actual line sets needed for specific solar systems is acceptable and would eliminate the need to ensure straight runs from the roof to the attic since the line sets can be installed with bends and turns. This may reduce costs now or in the future. With this option, at least one conduit must be run for a future photovoltaic (PV) system.
- The most common solar panels need either two 9.5 mm (3/8") dia. or two 19 mm (3/4") dia. insulated copper lines. However, choosing to install a specific line set may restrict homeowners' options for future solar thermal system installations.

3. Pre-installed Plumbing Connections for Future Solar Tank:

Typical solar thermal systems require the installation of a separate storage tank. Install valves and fittings to make future connections simple and affordable.



3. Solar Ready Program Requirements - Plumbing Connections:

(Refer to Diagram 3.1)

- 3.1 Provide two tees connections in the cold water inlet pipe that delivers cold water to the main (existing) water heater.
- 3.2 Provide shut-off valves on each of the tees and one on the main pipe between the two tees to allow for the quick connection of a future tank.

Sample installation with a solar hot water tank on the left connected to the regular hot water heater on the right.

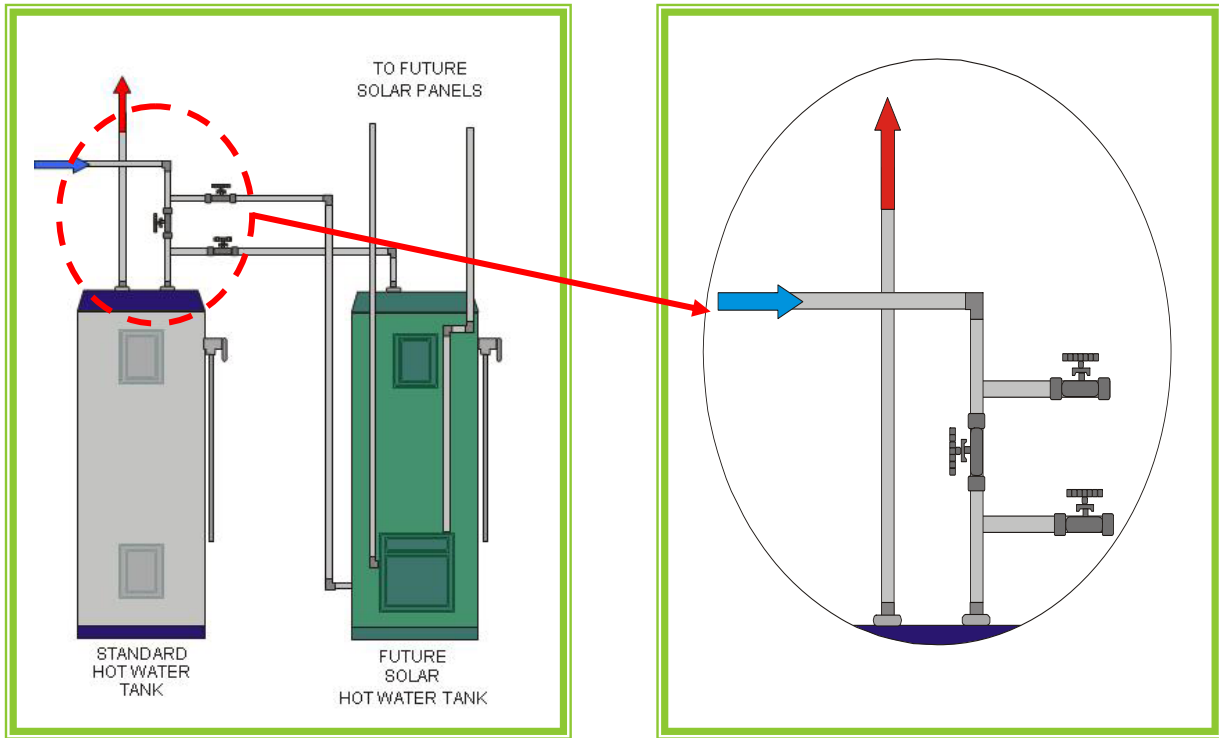

Diagram 3.1 Plumbing Connections

4. Provide an Electrical Outlet Near the Planned Water Tank Location:

Most solar thermal systems will require an electrical outlet for pump or control operation. Ensure a 110 volt plug is easily accessible. Space should also be left for the electrical panel or inverter needed for a future PV system. This could be in the mechanical room or near the main electrical service panel. Wall space of 1 m² (3' x 3') will be sufficient.

4. Solar Ready Program Requirements – Electrical Connections:

- 4.1 Provide one 110 volt outlet within 1.5 m (5') of the planned solar water tank location - the outlet can be on the same circuit as a power vented water heater;
- 4.2 Provide 1 m² (3' x 3') of wall space for a PV system connection or inverter.

5. Location of Components on the Construction Plans:

It is important that all of the elements needed for future installation of a solar system be identified on the construction plans for future reference. This will make it easier for homeowners and contractors to install the future system cost effectively. A simple diagram for the homeowner showing key component locations is desirable.

5. Solar Ready Program Requirements – Construction Plans Identification:

On the construction plans and homeowner's diagram clearly identify:

- 5.1 the roof location(s) for solar panel installation (Diagram 1.1 on page 2);
- 5.2 the location of the conduit(s) or line set and conduit (Diagram 2.1 on page 3);
- 5.3 a 1 m² (3' x 3') floor location that will accommodate a future solar storage tank in the mechanical room (Diagram 2.1 on page 3);
- 5.4 1 m² (3' x 3') of wall space for a photovoltaic system connection or inverter.

6. Label the Solar Ready Components:

Solar Ready components should be clearly identified for the future homeowners. This will assist both in marketing and in the future installation of solar energy systems. Labels are available for ordering through NRCAN. Visit www.newhomes.nrcan.gc.ca for more information.

6.1 Solar Ready Program Requirements - Solar Ready Labels:

- 6.1 Provide small (5 cm x 7.5 cm) Solar Ready labels on the basement end(s) of the conduit(s) or the installed line set and conduit.
- 6.2 Provide a large (10 cm x 15 cm) Solar Ready label on the main hot water tank.

Sample Label



7. Typical Costs for Solar Ready:

• Plumbing	\$ 60 - \$100	Plumber to install shut off valves
• Electrical Outlet	\$ 30 - \$ 50	Electrician to add outlet
• 2-5cm Central Vac Conduits	\$150 - \$180	Contractor to place conduits
• Design Time (per plan-set)	\$ 35 - \$ 50	Designer to verify plans for roof layout & conduit placement
• Labels	\$ 5	Contractor to order labels
• Total Estimated Cost	\$280 - \$380	

8. Solar Ready Marketing:

NRCAN has developed a Solar Ready graphic which may be used in promotional materials. A brochure, *Are You Solar Ready?* explaining the benefits and features of a Solar Ready new home is available for distribution to interested home buyers. Builders may order large and small labels for hot water tank and conduit labeling. Additional information on Solar Ready new homes is available at www.newhomes.nrcan.gc.ca

9. What can you expect from your Solar Ready home?

The Solar Ready provisions in this specification will make it easier and more cost efficient for homeowners to install, within the 9.3 m² (100 sq. ft.) of roof area and based on current technologies, either:

- up to two panels for a roof-mounted solar domestic hot water system (which can provide up to 50%-60% of a typical families hot water needs) OR
- up to a 1.25 kilowatt (kW) photovoltaic system to generate electricity OR
- a combination of one solar domestic hot water panel and up to 0.65kW of photovoltaic panels to generate electricity.

This makes the homes you build today even better in the future. Solar ready is a cost effective way to empower homeowners to benefit from solar technologies.

Solar Ready Checklist	
Program Requirements	Verified
1. Roof Location: 1.1 at least 9.3 m ² of unobstructed area (min. 2.9 m dimension), 1.2 orientation SE to W or 2 locations noted on plans, 1.3 roof pitch between 5/12 and 12/12.	<input type="checkbox"/>
2. Conduit Provisions: 2.1 two 5cm diameter or one 10 cm diameter plastic pipe(s) that run from an accessible attic or roof to a planned mechanical room.	<input type="checkbox"/>
3. Plumbing Connections: 3.1 two tee connections on the water heater's cold water inlet line; 3.2 shut off valves on both tees and on the main pipe between the tees.	<input type="checkbox"/>
4. Electrical Connections: 4.1 a 110 volt outlet located near the hot water heater; 4.2 1m ² available wall space for PV system connection or inverter.	<input type="checkbox"/>
5. Construction Plan Identification/Homeowner's Diagram: 5.1 the roof location(s) for solar panel installation; 5.2 the location of the conduit(s) or line set; 5.3 the 1 m ² area for the future solar storage tank in the mechanical room; and 5.4 1 m ² of wall space for a PV system connection or inverter.	<input type="checkbox"/>
6. Solar Ready Labels: 6.1 small Solar Ready labels on the basement end(s) of the conduit(s) or the installed line set and conduit; 6.2 a large Solar Ready label on the main hot water heater.	<input type="checkbox"/>